



HYUNDAI
Commercial Vehicles

EX8



CAB CHASSIS

KEY FEATURES

Driver's Suspension Seat

Smart Key Entry with Security System

Vehicle Dynamic Control (VDC)

High Power Assist Brake (HAB)

Easy Hill Start (EHS)

Cruise Control

KEY SPECIFICATIONS

GVM 7,800kg **GCM** 11,300kg

Wheelbase (Super Cab) LWB 4,050mm ELWB 4,400mm

Engine 3.9L, Diesel Turbo Euro 5

Max Power 127KW (170HP) / 2,500RPM

Max Torque 608NM / 1,400 RPM

"READY BUILT, READY TO WORK"

ENGINE & DRIVELINE

● ENGINE EURO 5 COMPLIANT

Engine	4 Cylinder 16 valve SOHC
Displacement	3,933cc
Max Power	127KW (170HP) @ 2,500 RPM
Max Torque	608NM / 1,400RPM
Turbocharger	Intercooler Turbo Charger
Compression Ratio	17.0 : 1
Bore x Stroke	103mm x 118mm
Injection System	Denso Common Rail System
Emission Control System	Cooled EGR Particulate Matter Catalyst

● PERFORMANCE

PERFORMANCE (Calculated)	SUPER CAB LONG
Speed at Max. Engine Speed	136KPH
Grade Ability at Rated GVM	45.3%
Grade Ability at Rated GCM	30.6%
Min Turning Cycle (m)	5.3 / 7.5 / 8.2

● TRANSMISSION (T60S6)

Type	5 speed manual Synchronesh on gear 1~5
Gear Ratio	1 st 6.701 2 nd 3.712 3 rd 2.084 4 th 1.351 5 th 1.000 6 th 0.732 Rev 5.983
PTO Opening	PTO provision on LHS of transmission case

● AXLES

Front	Type	Reverse Elliot I-Beam
	Capacity	3,100 kg
Rear	Type	Full Floating Type
	Capacity	4,700kg
Final Drive Ratio		4.625 : 1

● SAFETY FEATURES

- Vehicle Dynamic Control (VDC)	- Electronic Stability Control (ESC)
- High Power Assist Brake (HAB)	- Anti-lock Braking System (ABS)
- Easy Hill Start (EHS)	- Traction Control System (TCS)
- Engine Drag Control (EDC)	- Electronic Brake Force Distribution (EBS)
- Daytime Running Lamps	

● BRAKES

Drum Diameter	Front	320 mm
	Rear	320 mm
- ABS with electronic brake force distribution (EBD)		
Service Brake	Hydraulic with vacuum servo assistance dual circuit	
Exhaust Brake	Vacuum operated, butterfly valve type	
Parking Brake	190mm diameter drum park mounted on rear of transmission	

● ELECTRICAL

Type	24V electrical system
Batteries	2 x MF90AH maintenance free batteries connected in line
Alternator	24V, 55Amp
Starter Capacity	5.0KW Starter Motor
12V Power Outlet	12V maximum, 36W

● CLUTCH

Type	Hydraulic control, diaphragm spring single dry plate and pre-damper
Disc Diameter	ø 362 mm

● PROPELLER SHAFT (DS300)

TYPE	Tubular, forged steel ends without centre bearing
------	---

● WHEELS AND TYRES

Wheels Type	Single Front, dual rear 17.5 x 6, 6 Stud
Tyre Size	205/75R 17.5 Front x 2 205/75R 17.5 Rear x 4
Tyre Rating	Steer 1,450kg x 2 Drive 1,400kg x 4
Spare Wheel Tyre	1 Mounted

CAB & CHASSIS EQUIPMENT

● CAB INTERIOR

Driver's Seat	Ergonomic adjustable suspension seat
Passenger Seats	Two seat capacity, independently adjustable seats with a storage console
Seat Headrest	Height adjustable headrest 's
Steering Wheel	Tilt & telescopic adjustable steering wheel column, audio controls with hands free
Cruise Control	Auto integrated - Steering Wheel Mounted
Interior Finish	Fully cloth, padded roof lining and all weather PVC flooring covering
Air Conditioning	Fully integrated with heater and defrost modes, 4 speed fan
Audio	System supports Bluetooth, USB, CD player, Radio, MP3 and AUX
Windows	Electric operated
Power outlets	1 x 12v, 1 x 24V
Keyless Entry	With control door locking and Anti-theft Smart Key
Interior Lamps	2 x 10Watt & 1 x 30Watt
SIWS	Service Indicator Warning System
Sun Visors	Driver's and passenger's
Grips	Door and side pillar entry assist grips

● CAB EXTERIOR

Cab Mounting	Semi-floating
Windshield	One piece laminated
Windscreen Wipers	Dual electric 3 speed with washer
Side Glass	With inbuilt UV ray protection
Side Mirrors	Heated main vision mirrors
Headlights	Vertical styled with turn signals
Fog Lamps	Projection type with daytime running lights
Reverse Alarm	Standard feature

● CHASSIS FRAME

Type	H frame with channel sectional side rail & Cross Members
Side Rail	Reinforced with outer stiffeners. Main section side rail dimensions: 183mm x 60mm x 6.0mm

● SUSPENSION

Front	Type	Semi-elliptic laminated leaf springs
	Size x Leaves	1200 x 70 x 11t-2, 11t-1
	Shock Absorber	Gas filled telescopic type
Rear	Type	Semi-elliptic laminated leaf springs
	Size x Leaves	1250 x 70 x 10t-5, 11t-1
	Rear Spring Helper	990 x 70 x 15t-3

● STEERING

Type	4 spoke ball and nut type with telescopic steering column	
Maximum Angle	Inside Wheel	44.5°
	Outside Wheel	32.0°

● FUEL TANK

Type	Frame mounted steel with a lockable fuel cap
Capacity	100L

DIMENSIONS & WEIGHTS

● DIMENSIONS (MM)

DIMENSIONS (MM)	LWB	ELWB
Wheelbase	4,050	4,400
Overall Length	6,870	7,370
Overall Width	2,028	2,028
Overall Height	2,285	2,290
Front Overhang	1,125	1,125
Rear Overhang	1,630	1,780
Front Track	1,680	1,680
Outside Rear Track	1,650	1,650
Rear Frame Width	860	860
Cab to Axle	3,160	3,510
Cab to End of Frame	4,790	5,290

● WEIGHTS (KG)

WEIGHTS (KG)	LWB	ELWB
Gross Vehicle Mass	7,800	
Gross Combination Mass	11,300	
Front Loading Limit	3,100	
Rear Loading Limit	4,700	
Total CAB Chassis Mass	2,810	2,835
Front CAB Chassis Mass	1,875	1,925
Rear CAB Chassis Mass	935	910

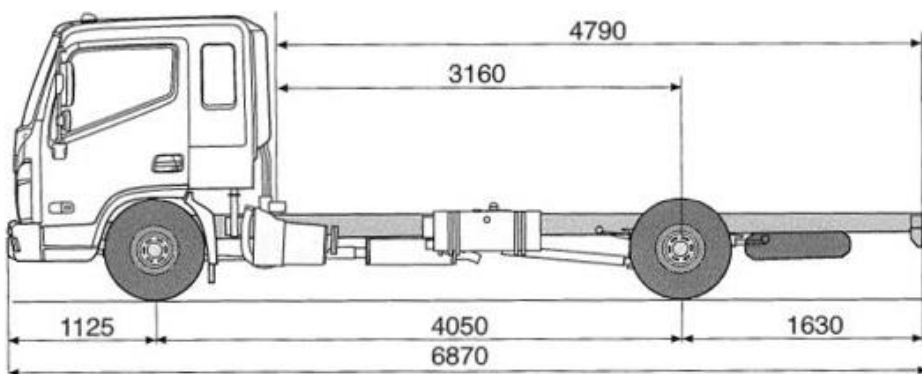

<Long Wheel Base>

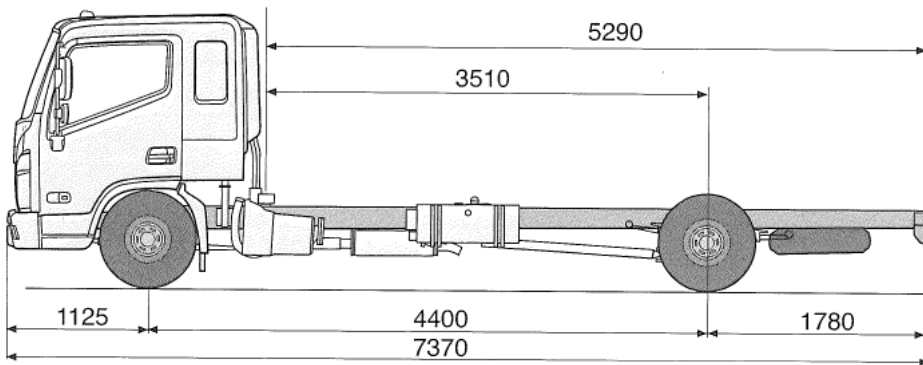

<Extra Long Wheel Base>

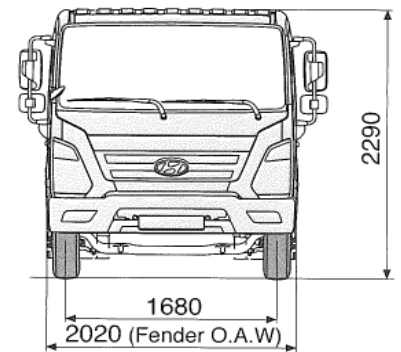

You're never alone on the road in a Hyundai EX series truck. When you're covered by Hyundai's 24/7 nationwide truck roadside assist, you'll never find yourself stranded

**24/7 TRUCK
ROADSIDE
ASSISTANCE**

Wherever you and your load go in a Hyundai EX Series truck, the roads are paved with the peace-of-mind Australia's 3-year 200,000km warranty.

**3YEAR
200,000km
WARRANTY**

Hyundai Commercial Vehicles Australia (HCVA) 376 Edgar Street, Bankstown NSW 2200

Hyundai Commercial Vehicles Australia (HCVA) reserves the right to alter vehicle specifications and equipment levels without notice. Some equipment featured on the vehicle in this brochure may not be available in Australia or may be optional to the extent permitted by the law. HCVA shall not be liable to any person as a result of reliance on the content of this brochure.

Please consult your Hyundai Commercial Vehicle Dealer for the latest specifications, equipment levels, options, prices, colours and vehicle availability. Metallic Paint is an optional extra. Note: Information in this brochure is current as at 19/04/2018